

# 815 - 909 PLUS

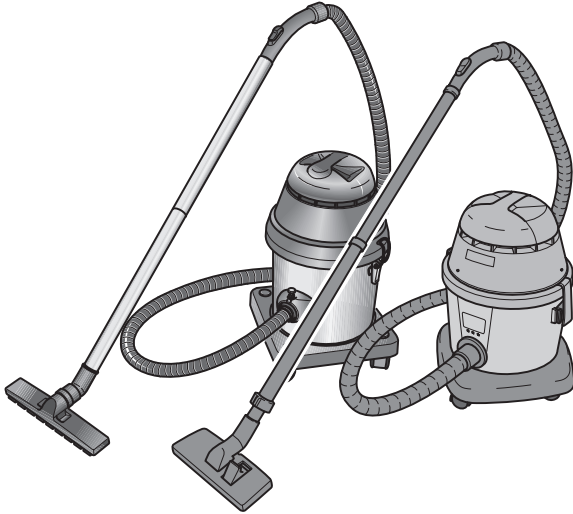





**EN** Use and Maintenance

**CE**

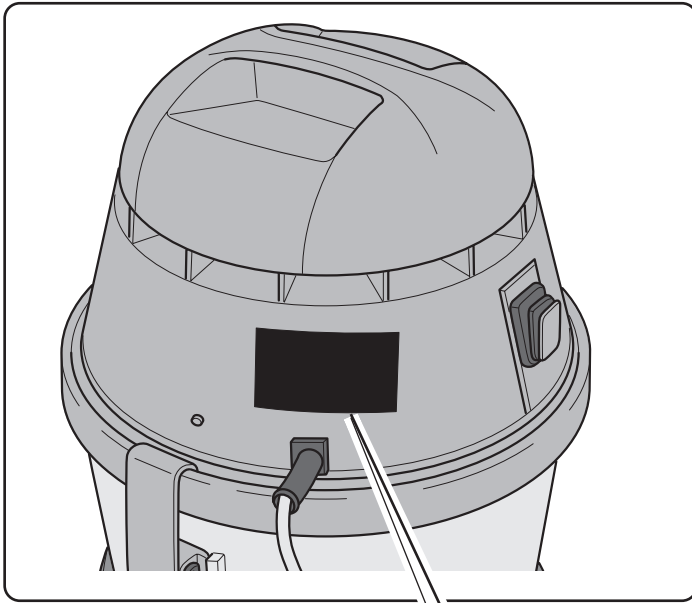
23-130009  
ed. 10/2025





1		  	MADE IN ITALY	
	Dry Vacuum Cleaner	Mod:	<input type="text"/>	2
9	<input type="text"/>	Art.:	<input type="text"/>	3
	<input type="text"/>	Year:	<input type="text"/>	
	Cap.ty: <input type="text"/>	Vac.: <input type="text"/>	Air flow: <input type="text"/>	
	Weight: <input type="text"/>	S/N: <input type="text"/>		
	4      7	5	8      6	

	1	2	3
IT	Produttore	Modello	Articolo
UK	Manufacturer	Model	Article
FR	Producteur	Modèle	Article
DE	Hersteller	Modell	Artikel
ES	Fabricante	Modelo	Artículo
PT	Produtor	Modelo	Artigo
NL	Producent	Model	Artikel
CS	Výrobce	Model	Typ
RU	Изготовитель	Модель	Артикул
PL	Producent	Model	Artykuł
AR	الصانع	الطرز	النوع

	4	5	6
IT	Capacità fusto	Capacità aspirazione	Portata d'aria
UK	Container capacity	Vacuum	Air flow
FR	Capacité de la cuve	Capacité d'aspiration	Débit d'air
DE	Fassungsvermögen des Körpers	Ansaugleistung	Luftdurchsatz
ES	Capacidad del bidón	Capacidad de aspiración	Caudal de aire
PT	Capacidade do reservatório	Capacidade de aspiração	Caudal de ar
NL	Inhoud reservoir	Zuigcapaciteit	Luchtdebiet
CS	Obsah nádoby	Sací výkon	Množství dopravovaného vzduchu
RU	Емкость бака	Мощность всасывания	Расход воздуха
PL	Pojemność zbiornika	Podciśnienie (mbar)	Przepływ powietrza
AR	سعة الخزان	قدرة الشفط	تدفق الهواء

	7	8	9
IT	Peso macchina	N° Matricola	Caratteristiche elettriche
UK	Machine weight	Serial N°	Electrical characteristics
FR	Poids machine	N° Matricule	Caractéristiques électriques
DE	Maschinengewicht	Matrikelnr.	Elektrische Eigenschaften
ES	Peso de la máquina	N° Matrícula	Características eléctricas
PT	Peso da máquina	Número de série	Características elétricas
NL	Machine gewicht	Serienummer	Elektrische eigenschappen
CS	Hmotnost stroje	Výrobní č.	Elektrické údaje
RU	Вес машины	Заводской №	Электрические характеристики
PL	Hmotnost stroje	Nr. Fabryczny	Właściwości elektryczne
AR	وزن الآلة	الرقم التسلسلي	المواصفات الكهربائية

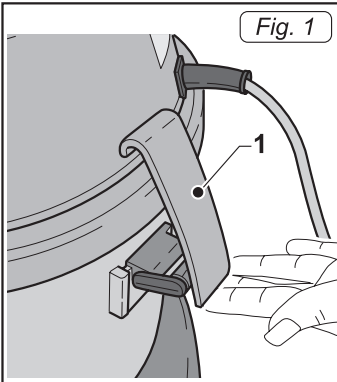

Fig. 1

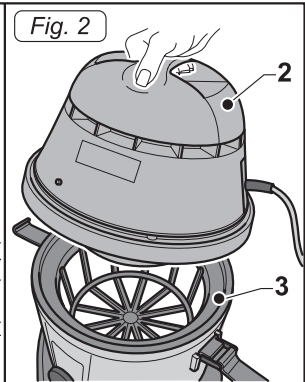

Fig. 2

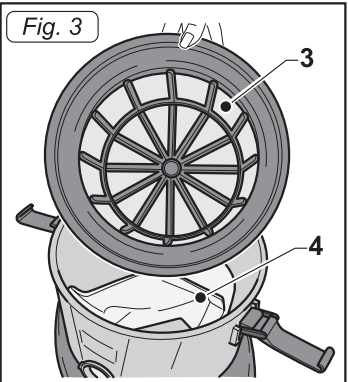
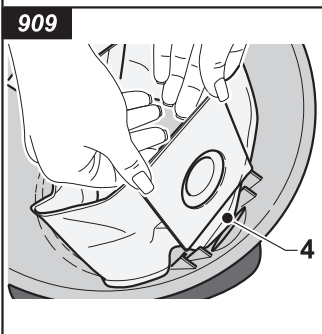
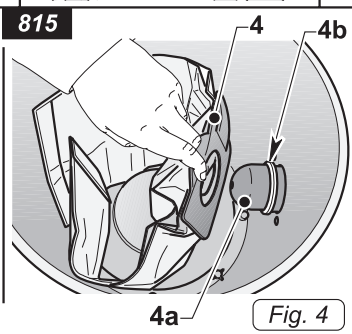

Fig. 3



909



815

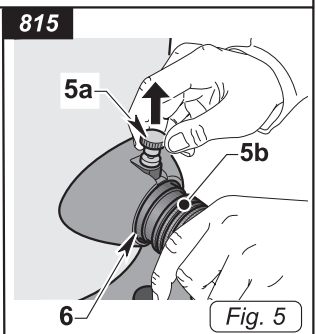

815

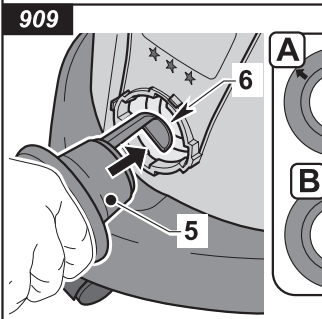

909

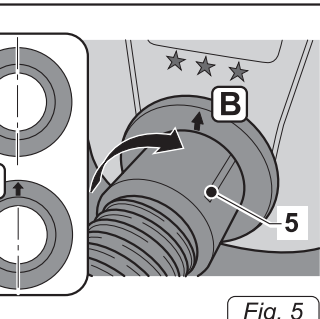

Fig. 5

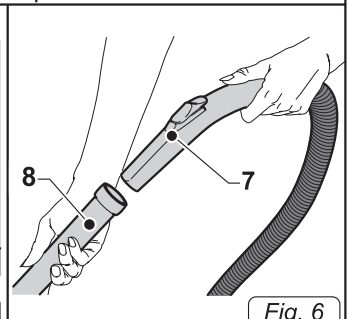
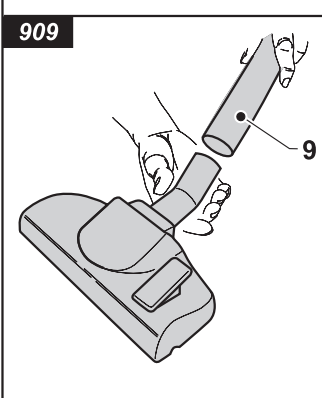
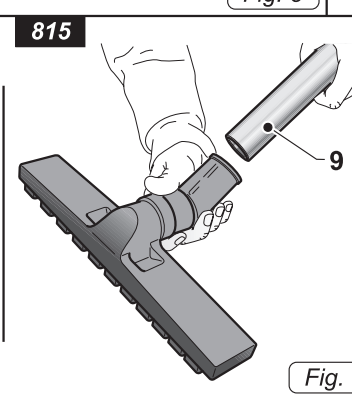

Fig. 6



909



815

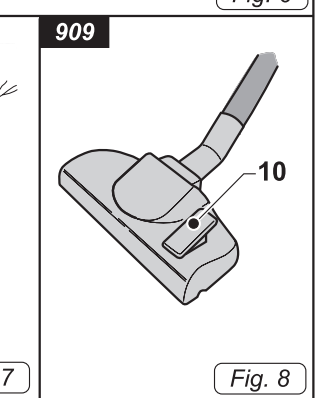

909

Fig. 7

Fig. 8

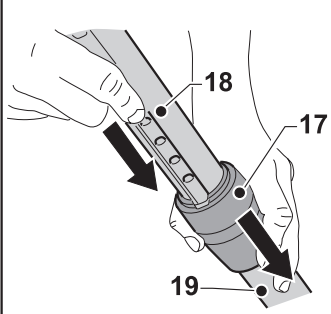
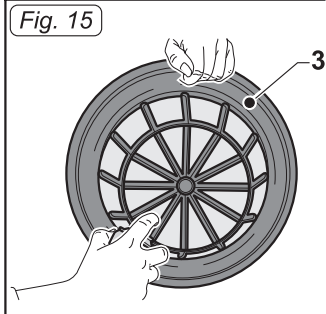
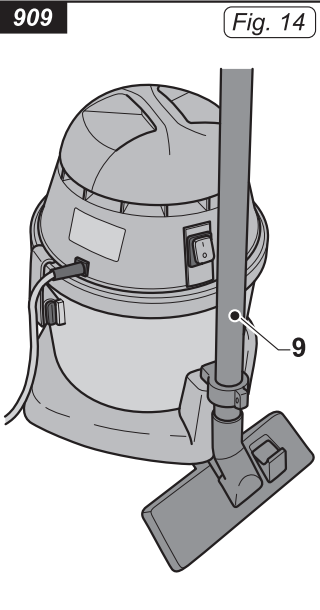
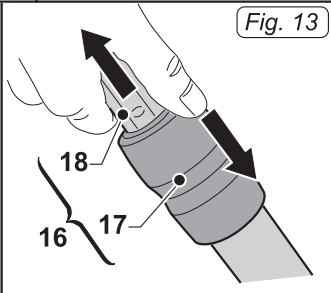
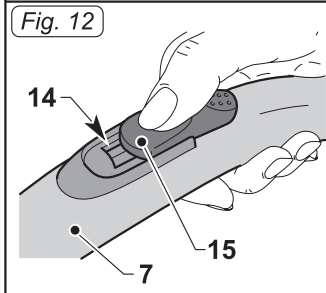
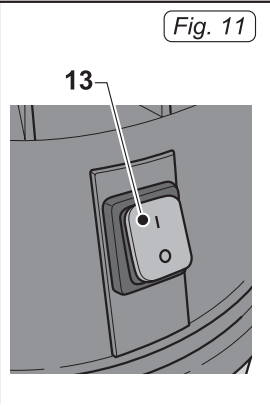
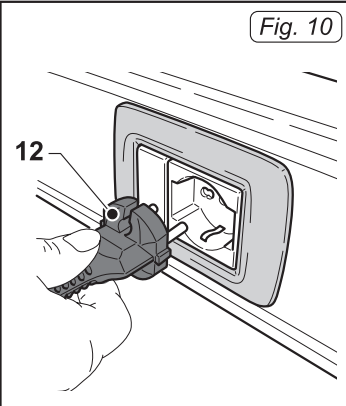
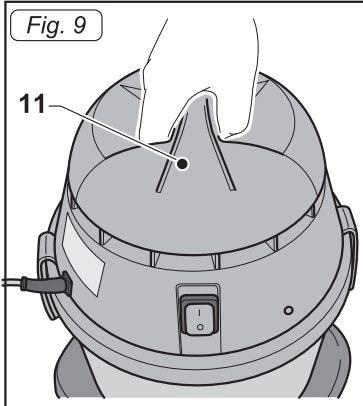





English ..... ENGLISH - 1  
*(Translation of original instructions)*



## TECHNICAL CHARACTERISTICS

Voltage .....	220-240 V
Motor power .....	800 W (909) 800 W (815)
Sound level .....	62 dB(A) (909) 65dB(A) (815)
Negative pressure .....	230 mbar
Paper bag capacity .....	12 l
Dimensions .....	320 x 320 x 520H mm (909) 340 x 340 x 570H mm (815)
Weight .....	6 kg (909) 8 kg (815 Plastic) 9 kg (815 Stainless steel)
Accessories .....	Ø 32 mm (909) Ø 36 mm (815)

## TYPE OF USE

Use this appliance only as a dry vacuum cleaner to suck up dust, crumbs etc. It has only been designed for this use.



### **DANGER:**

**The manufacturer can not be held responsible for any damage due to improper or incorrect use.**

**Any other use releases the manufacturer from liability for harm to persons and/ or property and invalidates any warranty condition.**

## IMPROPER USE

Do not use the appliance to:

- Suck up liquids of any kind;
- Suck up flammable, explosive, corrosive and/or toxic substances.
- Suck up hot substances.

Do not use the appliance in areas at risk of explosion.

## PREPARING THE APPLIANCE

### Checking the filter systems

- Release the levers (1 Fig. 1) and remove the cover (2 Fig. 2) complete with the motor unit.
- Remove the polyester filter (3 Fig. 3).
- Check that the paper bag (4 Fig. 3) is assembled inside the appliance.
- If the paper bag (4 Fig.3) is not present, mount it as follows:

#### **909P**

Insert the square cardboard rigid part into the slot on the drum.

#### **815**

Fit the paper bag (4 Fig.4) into the nozzle (4a Fig. 4) until passing the collar (4b Fig.4).

- Replace the polyester filter (3 Fig. 3).
- Replace the cover and lock it using the levers (1 Fig. 1).

### Assembling the piping

#### **909P**

Insert the sleeve with bayonet coupling (5 Fig. 5) into the hole (6 Fig. 5), moving the arrow on the sleeve (5 Fig. 5) to position "A", then turn the sleeve clockwise until it locks (arrow in position "B").

#### **815**

Lift the knob (5a Fig. 5) and insert the sleeve (5b Fig. 5) in the hole (6 Fig. 5) until it can't go any further and then release the knob.

- Attach the extension (7 Fig.6) to the ergonomic handle (8 Fig.6).
- Attach the required accessory (suction tool, dusting brush, crevice tool, multi-purpose brush etc.) to the rigid extensions (9 Fig.7).

## Multi-purpose brush (if present)

The multi-purpose brush should be used as follows:

- To clean hard floors, parquet etc.: press the lever (10 Fig.8) back to extract the brush bristles.
- To vacuum on carpets, rugs etc.: press the lever (10 Fig.8) forwards to retract the brush bristles.

## USING THE APPLIANCE



**N.B.**

The appliance can only be used if the paper bag is inserted correctly.

- The appliance is equipped with wheels and during use can be dragged along using the hose.
- To lift it up, insert your fingers into the handle (11 Fig.9) on the top of the cover

## Switching on the appliance

- Insert the plug (12 Fig.10) into the socket.
- Set the switch (13 Fig.11) to "I". The appliance starts up: the light on the switch comes on.



**N.B.**

The suction force can be adjusted using the selector (15 Fig.12) located on the ergonomic handle (7 Fig.12).

Opening up the window (14 Fig.12) gives lower suction power.

## Using the telescopic tube (if present)

- The length of the telescopic tube (16 Fig. 13) can be adjusted as follows:
- To lengthen the tube, press down on the ring nut (17 Fig. 13) and simultaneously extract the top part (18 Fig. 13) of the tube. Once the required length has been obtained, release the ring nut (17 Fig. 13) the tube will lock into the nearest locking position;
- To shorten the telescopic tube, use one

hand to push the ring nut (17 Fig. 13) down and the other to reinsert the top tube (18 Fig. 13) into the lower sleeve (19 Fig. 13).

## Switching off the appliance

- Set the switch (13 Fig.11) to "0" to switch off the appliance. The light on the switch goes off.
- Remove the plug (12 Fig.10) from the socket.
- **909P**  
Couple the tube (9 Fig.14) to the joint.

## CLEANING AND MAINTENANCE



**DANGER:**

**Before performing any maintenance, unplug the appliance from the mains.**

## Removing and replacing the paper dust bag

- Release the levers (1 Fig. 1) and remove the cover (2 Fig. 2) complete with the motor.
- Remove the polyester filter (3 Fig. 3).
- Remove the paper dust bag (4 Fig. 3) and replace it as described previously.
- Reassemble everything proceeding in reverse order compared to assembly.

## Checking and cleaning the polyester filter

- Release the levers (1 Fig. 1) and remove the cover (2 Fig. 2) complete with the motor.
- Remove the polyester filter (3 Fig. 3).
- Clean the filter (3 Fig. 15) from the inside out with a blast of air. The filter (3 Fig. 15) can be washed in warm water but must only be replaced when completely dry. If it is too dirty, replace it.
- Reassemble everything proceeding in reverse order compared to assembly.

## Cleaning the appliance body

- Clean the appliance body using a cloth dampened with water or mild detergent.



**DANGER:**

**Do not wash the appliance using jets of water.**

## SPARE PARTS

### 909P

Pack of 5 paper filter bags Code MK-042

### 815

Pack of 5 paper filter bags Code 01-385

Polyester filter Code 20-214

PROBLEM	CAUSE	SOLUTION
The vacuum cleaner does not work.	Switch not pressed.	Press the switch.
	Not plugged in.	Insert the plug into the socket.
	No current.	Check the power line.
Suction is not satisfactory.	Paper bag full.	Replace the dust bag.
	Filter elements clogged.	Clean the filter elements.
	Accessories or tubes clogged.	Check and clean the hose and the suction tool.









DEALER



**Riello Cleaning Machines S.p.A.**

Registered Office

Via Enrico Fermi, 43 - 37136 Verona (VR) - Italy

Headquarters

Via Circonvallazione, 5 - 27020 Dorno (PV) - Italy

P. +39 0382 848811 - F. +39 0382 84668 - M. info@riellocm.com



[ghibli.com](http://ghibli.com) - [wirbel.it](http://wirbel.it)

