

SB 150 U13
SB 150 U16
C 150 U13
C 150 U16



EN Use and Maintenance



GH30-925
ed. 10-2017

IT**DATI IDENTIFICATIVI**

I dati identificativi e la marcatura "CE" della macchina sono posizionati sulla targhetta posta sul corpo macchina.

Si consiglia di trascrivere il modello della macchina e il relativo numero di matricola nella tabella riportata nella pagina seguente.

EN**IDENTIFICATION DATA**

The machine identification data and "CE" marking are located on the plate on the machine body.

It is advisable to note the machine model and serial number on the table on the next page.

FR**DONNÉES D'IDENTIFICATION**

Les données d'identification et le marquage « CE » de la machine se trouvent sur la plaque située sur le corps de la machine.

Nous vous conseillons de recopier le modèle de la machine et le numéro de matricule correspondant dans le tableau reporté sur la page suivante.

DE**KENNDATEN**

Die Maschinenkenndaten und die Aufprägung "CE" befinden sich auf dem Schild an der Maschine.

Wir empfehlen, das Maschinenmodell und die dazugehörige Matrikelnummer in die Tabelle auf der nachfolgenden Seite einzutragen.

ES**DATOS DE IDENTIFICACIÓN**

Los datos de identificación y la marca "CE" de la máquina están grabados en la placa colocada sobre la estructura de la máquina.

Se recomienda transcribir el modelo y el número de matrícula de la máquina en la tabla descrita en la siguiente página.

PT

DADOS IDENTIFICATIVOS

Os dados identificativos e a marcação "CE" da máquina estão na placa colocada no corpo da máquina.

Aconselha-se transcrever o modelo da máquina e o relativo número de série na tabela referida na página seguinte.

NL

IDENTIFICATIEGEGEVENS

De identificatiegegevens en de "CE"-markering van de machine bevinden zich op het plaatje dat op de machine is aangebracht.

We raden u aan het model en het serienummer van de machine in de tabel op de volgende pagina te vermelden.

NO

IDENTIFIKASJONSDATA

Identifikasjonsdataene og maskinens CE-merking er å finne på merkeplaten som er plassert på selve maskinen.

Vi anbefaler at du skriver ned maskinmodellen og tilhørende matrikelnummer i tabellen på neste side.

DK

TEKNISKE DATA

Maskinens identifikationsdata og EF-mærket er indeholdt på mærkepladen, som sidder på maskinkroppen.

Maskinens identifikationsdata og EF-mærket er indeholdt på mærkepladen, som sidder på maskinkroppen.

SV

IDENTIFIERINGSDATA

Maskinens identifieringsdata och CE-märkning anges på märkskylten som finns på maskinen.

Vi rekommenderar att ni kopierar maskinmodellen och tillhörande serienummer i tabellen på följande sida.

PL**DANE IDENTYFIKACYJNE**

Dane identyfikacyjne i oznakowanie "CE" urządzenia umieszczone są na tabliczce znamionowej znajdującej się na korpusie urządzenia.

Zaleca się wpisać model i numer seryjny urządzenia do tabeli znajdującej się na kolejnej stronie.

CS**IDENTIFIKAČNÍ ÚDAJE**

Identifikační údaje a označení stroje „CE“ jsou uvedeny na štítku umístěném na tělese stroje.

Doporučujeme, abyste model stroje a jeho příslušné výrobní číslo přepsali do tabulky uvedené na následující straně.

SK**IDENTIFIKAČNÉ ÚDAJE**

Identifikačné údaje a označenie stroje „CE“ sú uvedené na štítku umiestnenom na telese stroja.

Odporúčame, aby ste model stroja a jeho príslušné výrobné číslo prepísali do tabuľky uvedenej na nasledujúcej strane.

TR**TANIMLAYICI BİLGİLER**

Makinenin tanımlayıcı bilgileri ve "CE" işareti makine gövdesine yerleştirilmiş olan plakada belirtilmiştir.

Bir sonraki sayfada bulunan tabloya makine modeli ve ilgili seri numarasını yazmanızı tavsiye ederiz.

HU**AZONOSÍTÓ ADATOK**

Az azonosító adatok és a gépen található "CE" jelzés a gép testére erősített címkén található.

Ajánlatos a gép modellszámát és a következő oldalon levő táblázatban feltüntetett törzskönyvi számot feljegyezni.

RO

DATE IDENTIFICATOARE

Datele identificatoare și marcarea “CE” a mașinii se găsesc pe tăblița de identificare aflată pe corpul mașinii.

Se recomandă transcrierea modelului mașinii și numărul relativ matricolei în tabela redată în paginile următoare.

EL

ΤΕΧΝΙΚΑ ΣΤΟΙΧΕΙΑ

Τα τεχνικά στοιχεία και η σήμανση συμμόρφωσης “CE” της μηχανής βρίσκονται στην πινακίδα επάνω στο σώμα της μηχανής.

Συνοψίζεται η αντιγραφή του μοντέλου του μηχανήματος καθώς και του σχετικού σειριακού αριθμού στον πίνακα που βρίσκεται στην επόμενη σελίδα.

RU

ИДЕНТИФИКАЦИОННЫЕ ДАННЫЕ

Идентификационные данные машины и маркировка «CE» находятся на табличке, установленной на корпусе машины.

Рекомендуется переписать модель машины и соответствующий паспортный номер в таблицу, приведенную на следующей странице.

HR

IDENTIFIKACIJSKI PODACI

Identifikacijski podaci stroja i oznaka „CE“ su navedeni na pločici koja se nalazi na tijelu uređaja.

Preporučamo da prepisete model stroja i njegov serijski broj u tablicu koja se nalazi na sljedećoj stranici.

SR

IDENTIFIKACIONI PODACI

Identifikacioni podaci i oznaka “CE” mašine se postavljene na tabli a ista se nalazi na telu mašine.

Savetujemo Vam da napišete model mašine i serijski broj u tabelu koja se nalazi na sledećoj stranici.

FI

DATA TUNNISTAMINEN

Tunnistetiedot ja merkki “CE” koneen on sijoitettu levyn alla ohjauspaneelissa.

On suositeltavaa kopioida mallin konetta, ja sarjanumero taulukossa seuraavalla sivulla.

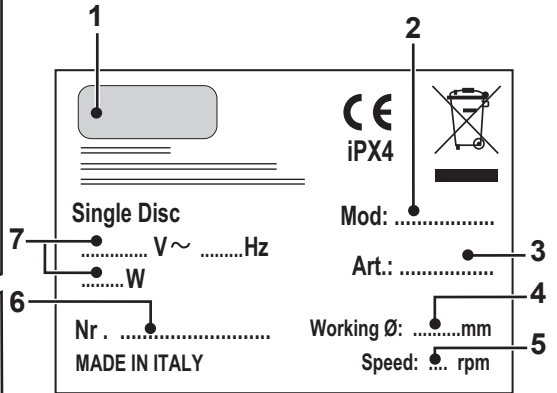
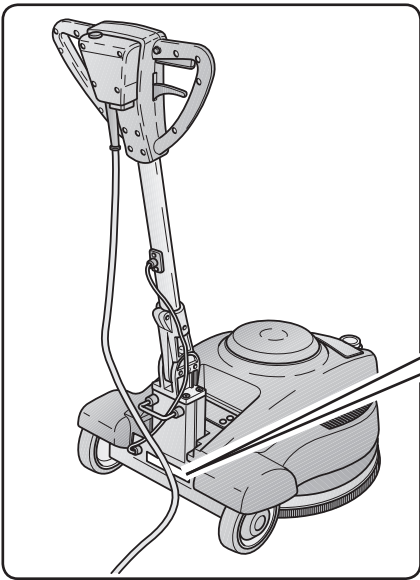

1	2	3	4	5	6	7
IT	Produttore	Codice articolo	Ø di lavoro	Velocità di rotazione	N° Matricola	Caratteristiche elettriche
EN	Manufacturer	Article code	Working Ø	Rotation speed	Serial number	Electrical characteristics
FR	Producteur	Code de l'article	Ø de travail	Vitesse de rotation	N° de Matricule	Caractéristiques électriques
DE	Hersteller	Artikelnummer	Ø Arbeit	Drehgeschwindigkeit	Matrikel-Nr.	Elektrische Eigenschaften
ES	Fabricante	Código del artículo	Ø de trabajo	Velocidad de rotación	N° de Matricula	Características eléctricas
PT	Fabricante	Código do artigo	Ø de trabalho	Velocidade de rotação	N° de Série	Características eléctricas
NL	Productent	Artikcode	Ø bewerking	Rotatiesnelheid	Serienummer	Elektrische eigenschappen
NO	Produsent	Artikkelkode	Driftsdiameter	Roteringshastighet	Matrikelnummer	Elektriske egenskaper
DK	Fabrikant	Artikelkode	Arbejdsdiameter	Omdrejningshastighed	Matrikelnr.	El-specifikationer
SV	Tillverkare	Artikelkod	Arbetsdiameter	Rotationshastighet	Serienummer	Elektriska egenskaper
PL	Producent	Kod artykułu	Ø pracy	Prędkość obrotów	Nr seryjny	Charakterystyka elektryczna
CS	Výrobce	Kód výrobku	Pracovní Ø	Rychlost rotace	Výrobní č.	Elektrické v lastnosti
SK	Výrobca	Kód výrobku	Pracovný Ø	Rychlosť rotácie	Výrobné č.	Elektrické vlastnosti
TR	Üretici	Ürün kodu	Çalışma çapı	Seri No	Dönüş hızı	Elektriksel özellikler
HU	Gyártó	Cikkszám	munka Ø	Forgási sebesség	Törzskönyvi szám	Elektromos sajátosságok
RO	Producător	Cod articol	Ø disc de lucru	Viteză de rotație	N° Matricolă	Caracteristici electrice
EL	Κατασκευαστής	Κωδικός προϊόντος	Διάμετρος εργασιών	Ταχύτητα περιστροφής	Σειριακός αριθμός	Ηλεκτρικά χαρακτηριστικά
RU	Изготовитель	Код изделия	Рабочий Ø	Скорость вращения	N° Паспорта	Электрические характеристики
HR	Proizvođač	Kod proizvoda	Ø rada	Brzina vrtnje	Serijski br.	Električne karakteristike
SR	Proizvođač	Šifra proizvoda	Ø rada	Brzina rotacije	Serijski broj	Električne karakteristike
FI	Tuottaja	Tuotenumero	Ø työ	Ryöimisnopeus	Tuotenumero	Sähköiset ominaisuudet

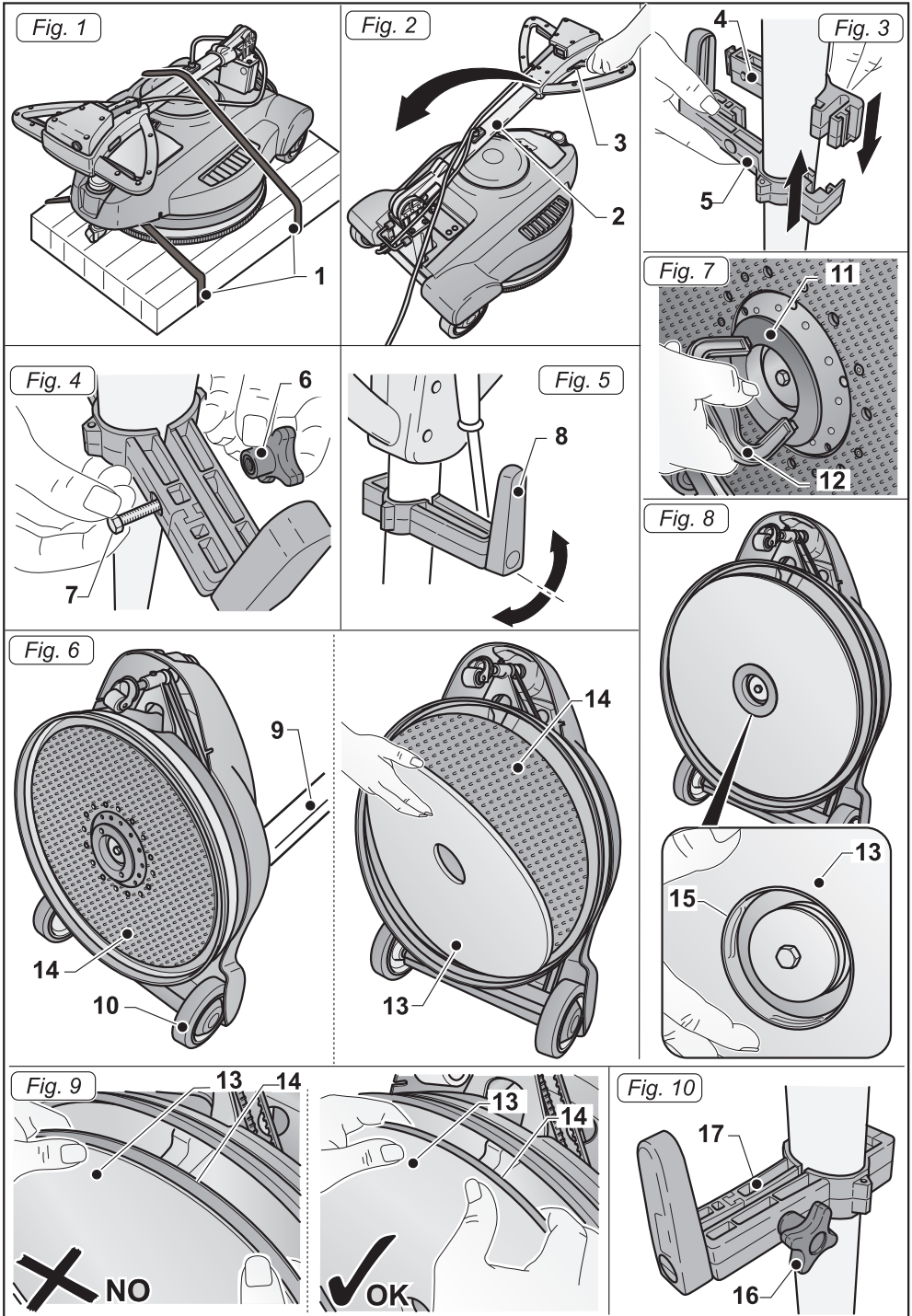

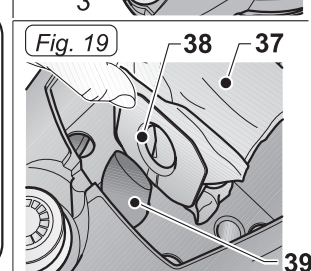
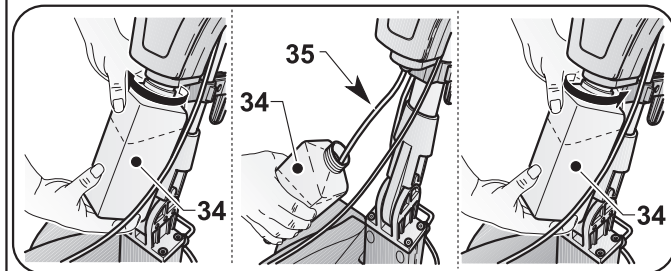
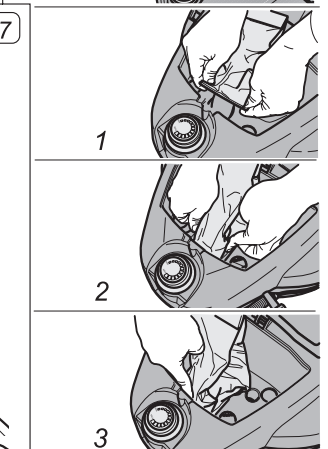
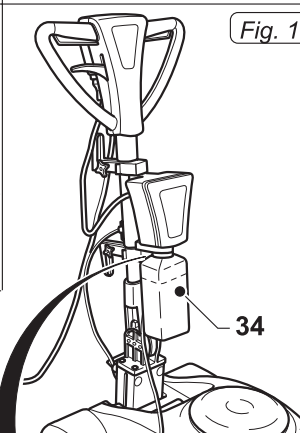
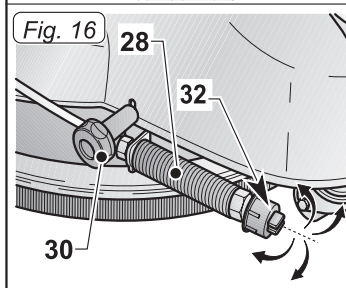
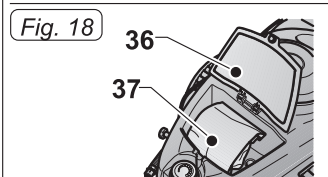
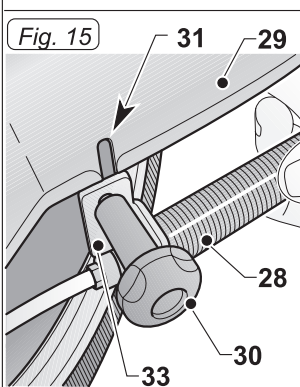
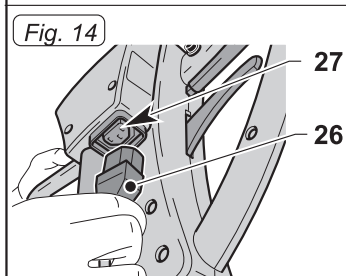
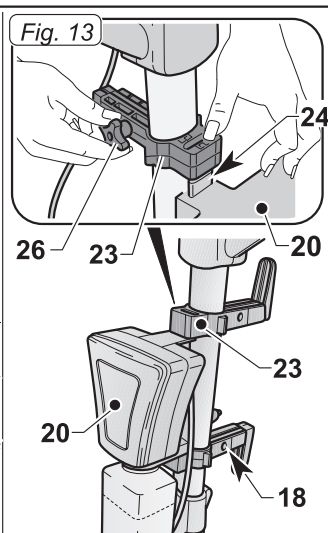
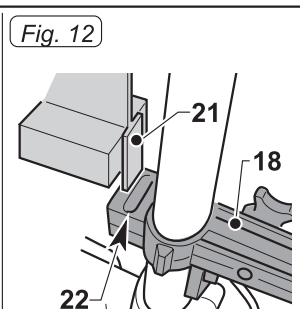
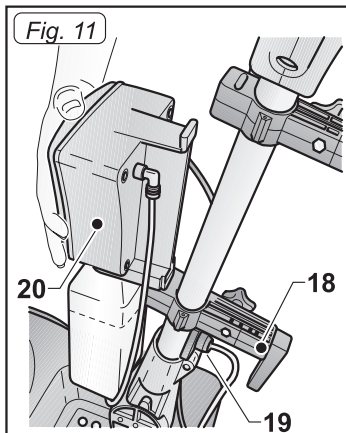

Fig. 21

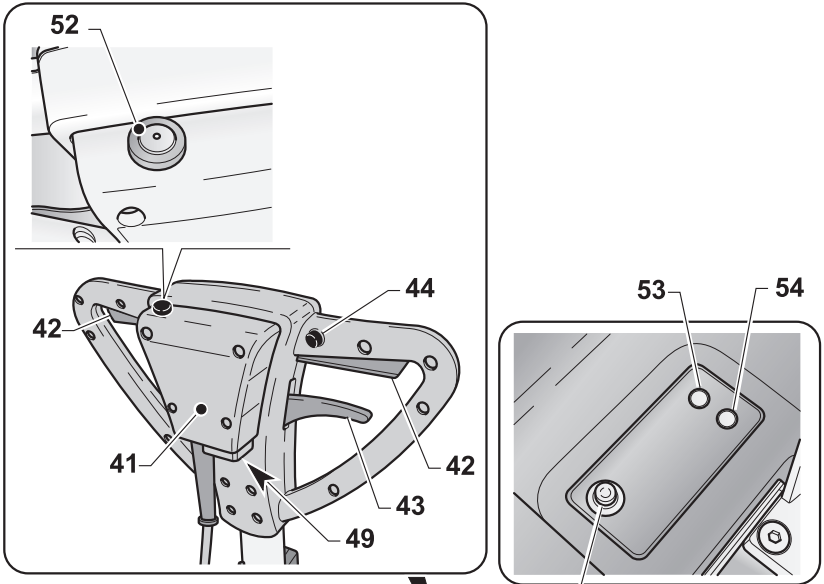

Fig. 20

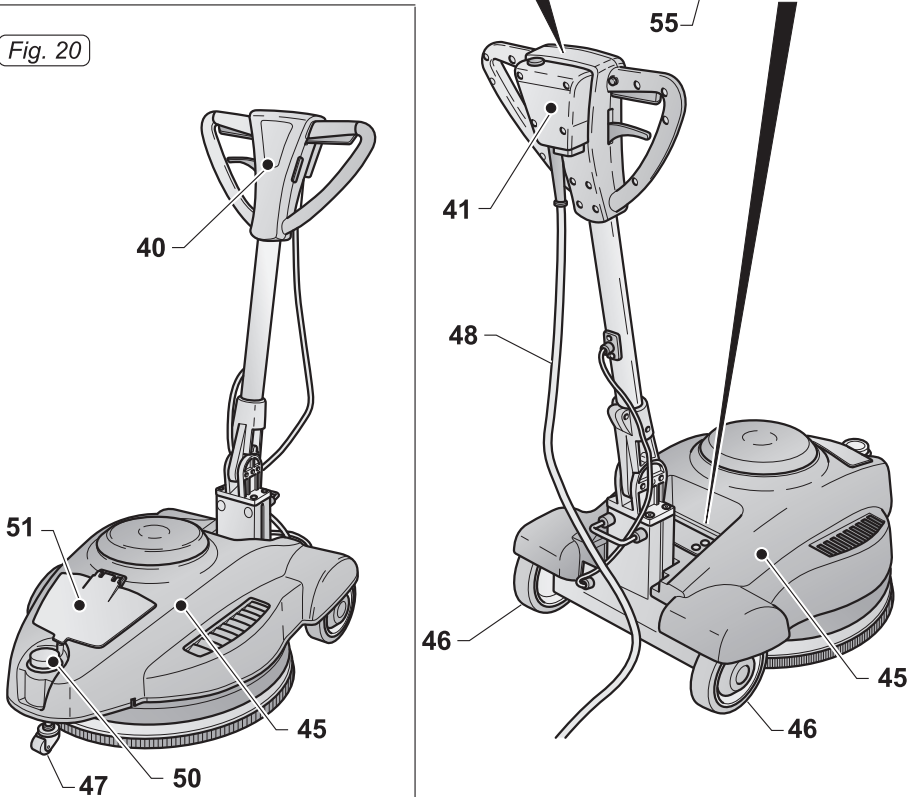

Fig. 22

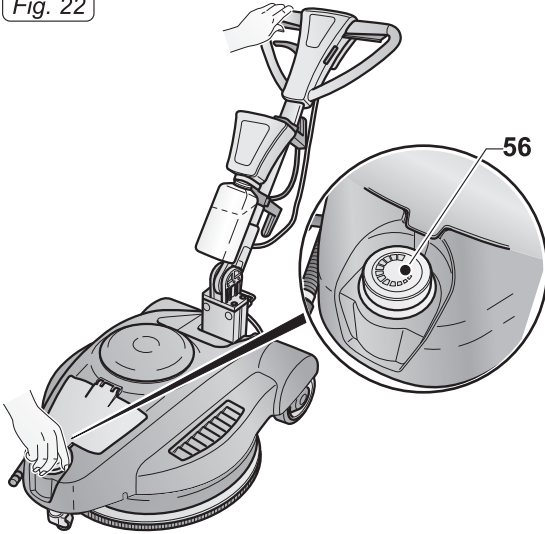

Fig. 23

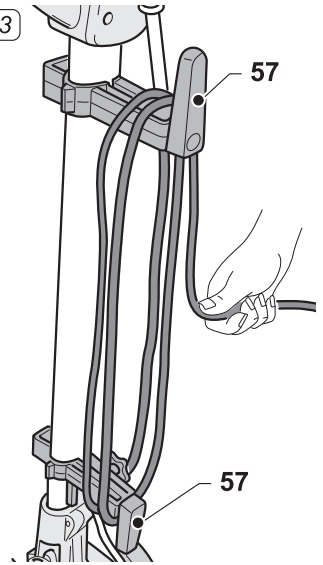

Fig. 24

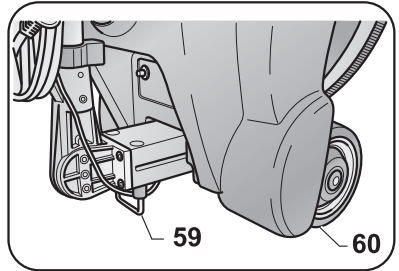
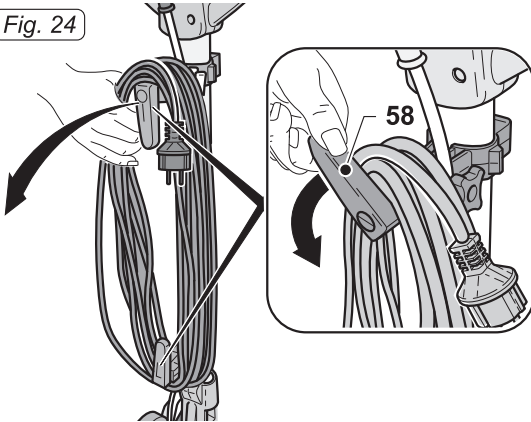
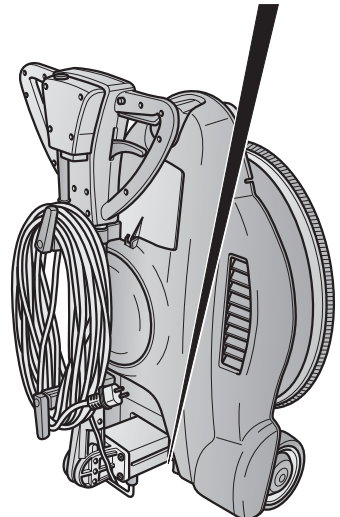
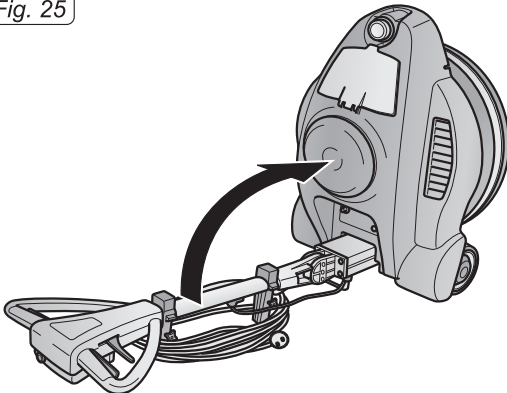

Fig. 25





English ENGLISH - 1
(Translation of original instructions)

*Dear Customer,
Thank you for choosing one of our cleaning products.*

The floor polisher you have purchased has been designed to satisfy users in terms of ease of use and reliability.

We are aware that, in order to remain so over time, a good product requires continuous updates aimed at satisfying the expectations of those who use it daily. To this end, we hope that you will be not only a satisfied customer but also a partner who does not hesitate to let us know your views and ideas resulting from personal experience on a day-to-day basis.

Contents

1.1 - TECHNICAL CHARACTERISTICS	EN-3
1.2 - INTRODUCTION	EN-3
1.3 - INTENDED MACHINE USE	EN-3
1.4 - NON-INTENDED MACHINE USE	EN-3
2.1 - UNPACKING	EN-4
2.2 - COMPONENT ASSEMBLY	EN-4
2.2.a - Assembling the cable reel supports	EN-4
2.2.b - Pad assembly	EN-4
2.2.c - Electric spray accessory assembly	EN-4
2.2.d - Filling the tank	EN-4
2.2.e - Paper dust collection filter assembly	EN-4
2.2.f - Electrical Connection	EN-5
3.1 KNOWLEDGE OF THE MACHINE	EN-5
4.1 HANDLE TILT ADJUSTMENT	EN-5
5.1 GUIDE HANDLE	EN-6
6.1 OPERATION	EN-6
6.1.a - Checks to be performed before use	EN-6
6.1.b - Starting up the machine	EN-6
6.1.c - Pad pressure adjustment	EN-6
6.1.d - Using the machine	EN-7
6.1.e - End of use and shutdown	EN-7
6.1.f - Transport	EN-7
6.1.g - Positioning the machine after use	EN-7
7.1 MAINTENANCE AND CLEANING	EN-8
7.1.a - Cleaning the machine	EN-8
7.1.b - Cleaning the spray accessory nozzle (Optional)	EN-8
7.1.c - Pad replacement	EN-8
PROBLEMS - CAUSES - SOLUTIONS	EN-9

1.1 TECHNICAL CHARACTERISTICS

SB/C 150	U13	U16
Voltage	230 V	
Frequency	50Hz	60Hz
Motor power	1300W	1600W
Working width	505 mm - 20 inch.	
Rotation speed	1500 rpm	1800 rpm
Weight without accessories	44 Kg	
Electrical cable length	15 m	
Sound level	< 70 db(A)	
Vibration level	< 2.5	
Working pressure	0÷5 Kg (adjustable)	
Transmission type	direct	
Maximum dimensions	1130x790x330H mm	
Minimum dimensions	855x790x485H mm	

1.2 INTRODUCTION



DANGER:

Before using the appliance, read the accompanying “**SINGLE DISC SAFETY WARNINGS**” booklet carefully.

This manual forms an integral part of the machine itself. It must therefore be kept in a safe place where it is accessible to all users (operators and maintenance personnel) throughout the life of the machine until it is scrapped.

1.3 - INTENDED USE OF THE MACHINE

The machine has been designed and built: for polishing floors that have been cleaned and vacuumed beforehand (i.e. parquet, marble, ceramic, linoleum etc.).



DANGER:

Any other use releases the manufacturer from liability for harm to persons and/or property and invalidates any warranty condition.

1.4 - NON-INTENDED USE OF THE MACHINE



WARNING:

The machine is not intended for outdoor use.



DANGER:

- do not polish uneven floors;
- do not use on cement floors;
- do not use on dirty floors;
- do not use diesel/petrol or corrosive detergents to polish floors;
- do not polish if corrosive, flammable and/or explosive liquids, even if diluted, are present.

2.1 UNPACKING (Figs. 1-2)

Upon delivery of the machine, remove its external packaging and cut the straps (1) (Fig. 1) and lift up the handle (2) by pulling on the release handle (3) (Fig. 2).

2.2 COMPONENT ASSEMBLY

2.2.a - Assembling the cable reel supports (Figs. 3/5)

The reel supports supplied must be mounted directly on the handle shaft:

- Fit the short coupling (4) into the long coupling (5) (Fig. 3).
- Tighten the knob (6) on the screw (7), keeping the latter to the right (Fig. 4).
- The hook (8) of the support can be rotated depending on usage (Fig. 5).
- Place one support on the top of the handle and a second support on the bottom.

2.2.b - Pad assembly (Figs. 6/9)

- Tilt the machine, pivoting, with the handle straight (9), with your feet on the wheels (10) and place it on the handle (Fig. 6).
- Unscrew the ring nut (11) using the handle (12) supplied (Fig. 7).
- Mount the pad (13) on the pad holder (14) (Fig. 9).
- Centre the pad (13) with the central guide (15) on the pad holder (14) and make sure the outer perimeter of the pad (13) corresponds with the outer perimeter of the pad holder (14) and then lock it on the pad holder's teeth pressing down with your fingers (Figs. 8-9).
- Use the pad for high-speed polishing (Gorilla or Cream Colour).



WARNING:

Use only pads supplied by the manufacturer for the specific machine model. Using other types of pads can compromise the safety of the machine.

2.2.c - Electrical spray accessory assembly (Optional) (Figs. 10/16)

- Loosen the knob (16) of the handle's upper support (17) (Fig. 10).
- Make sure that the lower support (18) rests on the plate (19) located on the handle rod (Fig. 11).
- Place the accessory (20) on the lower support (18), taking care to align the coupling tab (21) with its housing (22) (Fig. 12).
- Lower the upper coupling (23) and attach it to the coupling tab (24) on the top of the accessory (20) (Fig. 13).
- Tighten the knob (26) of the handle's upper support (23) (Fig. 13).
- Connect the power supply (26) to the auxiliary socket (27) (Fig. 14).
- Fit the nozzle (28) on the right part of the machine, inserting the plate (33) inside the casing (29) and the knob screw in the dedicated (30) housing (31), then tighten the knob (30) (Fig. 15).
- Make sure the nozzle (32) is in the horizontal position. The spray angle is 120 degrees, the nozzle position may be adjusted depending on specific requirements (Fig. 16).

2.2.d - Filling the tank (Fig. 17)

- Unscrew the tank (34) and remove it.
- Fill it with water and polishing wax. For dosing, refer to the instructions provided by the manufacturer of the polishing wax.
- Insert the suction tube (35) into the tank (34) and fully tighten.

2.2.e - Paper dust collection bag assembly (Figs. 18/19)

The machine is delivered with the bag already mounted.

- Lift the lid (36) and check that the bag (37) is correctly positioned (Fig. 18).

- If the bag is not present, to mount it, after having lifted the door (36), insert the suction tube (39) in the bag's (37) hole (38) (Fig. 18-19).
- Close the lid (36) which is held in position with a magnet (Fig 18).

2.2.f - Electrical connection

- Connect the machine power cable to a mains socket whose characteristics correspond to those shown on the machine's technical data plate.



WARNING:

- **Make sure the mains electrical system has a circuit breaker and has been earthed.**
- **Unwind the power cable completely before turning on the appliance.**
- **Use an extension cord only if in perfect condition and make sure the diameter is appropriate for the power of the appliance.**
- **Never allow the power cable to slide over sharp edges and do not crush it.**
- **The socket should be easily accessible.**
- **Make sure the electrical cable is not damaged.**

3.1 KNOWLEDGE OF THE MACHINE (Figs. 20-21)

- 40) Guide handle
- 41) Electrical control box
- 42) Pad rotation start levers (on-off)
- 43) Handle tilt lever
- 44) Pad rotation lever release button
- 45) Machine body
- 46) Wheels
- 47) Pivoting front wheel
- 48) Power cable
- 49) Auxiliary socket

- 50) Pad pressure adjustment knob
- 51) Bag access flap
- 52) Polishing wax spray start button
- 53) Red LED: when it lights up and stays lit, there is an excessive pad pressure on the floor.
(Risk of floor overheating with consequent floor burning)
- 54) Green LED: when lit the pad pressure on the floor is correct.
- 55) Motor thermal relay: enabled blocking motor operation when the machine operates with a excessive load.
To reset the thermal relay wait a few minutes for the motor to cool and then press the small button to activate the monitor.

4.1 HANDLE TILT ADJUSTMENT (Figs. 20-21)



WARNING:

The handle position must be adjusted while the appliance is at a standstill.

- Pulling the lever (43) the handle position can be adjusted (40); when the lever is released, the handle is positioned and locked in the closest position required.



NOTE:

Adjust the handle to a comfortable position, depending on your height, in order to easily push the machine in straight paths.
Never start the machine without having tilted the handle correctly.

5.1 GUIDE HANDLE (Fig. 21)

1) **Pad rotation lever release button (44)**
Press the button (44) to release the pad rotation start levers (42).

2) **Pad rotation start levers (42)**
Pulling the pad rotation levers (42) enables pad rotation.
When the levers (42) are released, pad rotation stops and the machine stops automatically.

The levers (42) should be kept pulled to achieve continuous machine operation.

3) **Polishing liquid spray button (52)**
When the button is pressed and held down, the polishing liquid spray is activated; if the button is released, the spray stops.



NOTE:

The spray works even when the pad is not rotating.

6.1 OPERATION

6.1.a - Checks to be performed before use

- If the electrical spray accessory is mounted (optional), check that it contains enough polishing liquid for the working phase and that the nozzle is properly connected and adjusted.
- Check the condition of the pad. If worn, replace it.
- Check that the appliance, particularly the mains cable, is not damaged in any way that might compromise correct machine operation or the operator's safety.

6.1.b - Starting the machine (Fig. 21)



WARNING:

**Do not start the machine if it is tilted.
Do not start the machine if the pad is not correctly mounted.**



NOTE:

The machine will not start if the handle shaft is upright.



DANGER:

Ensure your hands are dry before using the appliance.

- Pull the lever up (43) and lower the handle until it reaches the height desired.
- Press the button (44) to release the pad rotation start levers (42).
- Pulling the levers (42) starts the machine.
- When both levers (42) are released, the machine stops.



WARNING:

Never wrap the power cable around the neck or body of the machine.

6.1.c - Pad pressure adjustment (Fig. 22)

- Turn the handwheel (56) counter clockwise as far as possible (the pad is lifted up).
- Start brush rotation, the green led lights up.
- With your left hand keep the lever pressed down and with your right hand, turn the handwheel clockwise, until the red led lights up, then turn it counter clockwise until the green led lights up.
- Correct operation is when the red and green leds alternate.
- By turning the handwheel (56) clockwise the machine is lowered by increasing pressure on the pad.

If the handwheel (56) is turned counter clockwise, the machine is lifted, decreasing pressure on the pad.



WARNING:

If during operation the red led lights up and remains lit (not flashing), you must decrease pressure on the pad using the handwheel: do not use the machine if the red light is constant as the floor may be damaged.

6.1.d - Using the machine (Fig. 21)

- After starting the machine, begin polishing operations by keeping the levers (42) pressed, thus keeping the machine running and brush rotation active.
- The machine operates on straight line paths: it is therefore appropriate to treat a surface, starting from the perimeter zones while leaving the central areas for last. Polish by walking in a forward straight line up to where the cable length or room size permits, and then return polishing a parallel strip, making sure not to leave any spaces unpolished.



DANGER:

During operation, avoid passing over the power cable with the machine: this could cause serious damage and dangerous situations!

- The machine is also equipped with a passive aspiration system, designed to convey the fine dust generated during polishing to a convenient disposable paper filter, in front of the same.
- Use of the Spray accessory (optional) with a suitable chemical product will allow for removing any marks on the wax.



NOTE:

Using the machine in a fixed position with the pad rotation enabled for a prolonged period of time can cause damage to the floor.



NOTE:

When the levers (42) are released, pad rotation stops and the machine turns off

6.1.e – End of use and shutdown (Fig. 21 and 23).

- Release the levers (42) to stop pad rotation and turn off the machine (Fig. 21).
- Put the handle in an upright position.
- Remove the tank (Optional), empty the solution and clean the nozzle as indicated in the maintenance paragraph.



WARNING:

Do not leave the machine stopped if the pad is mounted and not raised in order to prevent them from being damaged.

- Unplug the power cable from the socket and wrap it around the cable reel supports.
- Roll up the cable on the supports (57) (Fig. 23).
- To remove the cable from the supports, turn the hooks (58) inward and remove the cable without necessarily unwinding it (Fig. 24).

6.1.f - Transport

Making sure that the mains plug is disconnected and the handle is in an upright position, lift the machine body by turning the handle downwards.

The machine can then be transported on the wheels.

6.1.g - Positioning the machine after use (Fig. 22 and 25).

After machine use, it can be stored in two ways:

Upright position with pad resting on ground (Fig. 22)

Place the handle in the upright position and then turn the handwheel (56) counter clockwise as far as it will go in order to lift the pad off the ground.

Upside down position (Fig. 25)

Load the machine on the handle as if you were to replace the pad.

Fully raise the handle.

The machine remains in a stable position, resting on the wheels (60) and the support (59).

7.1 MAINTENANCE AND CLEANING



WARNING:

For information and warnings relating to maintenance or cleaning, follow what is described in the "Safety warnings for single disc" manual, accompanying this document.

OPERATIONS TO BE CARRIED OUT DAILY

7.1.a - Cleaning the machine

Clean the machine with a damp cloth and then wipe it with a clean, dry cloth to prevent the formation of scale due to the effect of chemicals.



WARNING:

Do not use solvents, acids or corrosive substances for cleaning the machine.

If the pad is dirty, wash it at a maximum temperature of 60 °.

7.1.b - Cleaning the nozzle of the spray accessory (Optional) (Figs. 21 and 17).



WARNING:

Once you have finished polishing, you must drain and clean the water tank to prevent deposits or scaling and you must clean the nozzle.

- Remove the tank (34) (Fig. 17), empty the solution, rinse it and refill it with water.
- Position yourself with the machine near a discharge drain and press the button (52) (Fig. 21) until the tank is empty.

OPERATIONS TO BE CARRIED OUT WHEN NECESSARY

7.1.c - Pad replacement

The pad must be replaced when it is worn and its thickness is less than 10 mm; see the "Pad Assembly" paragraph for replacement instructions.



WARNING:

Use a pad with a 20" diameter 505 mm Type UHS.

TROUBLESHOOTING

PROBLEM	CAUSE	SOLUTION
Although the lever release button and brush rotation levers are pressed at the same time, the machine does not start.	The appliance is unplugged.	Plug the appliance in.
The pad holder does not rotate.	The brush/pad holder rotation lever is not pressed. Presence of foreign bodies.	Press the lever. Remove any foreign bodies stuck in the appliance.
Polishing liquid is not released.	The tank is empty. Button not pressed.	Fill the tank. Press the button.
Insufficient floor polishing.	Pad or chemical product not suitable. Pad worn.	Use a pad or chemical product that is appropriate to the type of floor to be polished. Replace the pad.
The machine operates erratically or vibrates heavily.	Check that the pad is perfectly centred in the pad holder. Pad not suited to floor type.	Replace the pad, centring it correctly in the pad holder. Use a pad suited to the floor surface.
The machine turns off unexpectedly during operation.	Motor thermal protection activation.	Restore the reset button until it "Clicks" and make sure to work in the correct range.

ghibli & wirbel

Professional Cleaning Machines Since 1968

DEALER



Cod. GH30-925 - 1[^] ed. - 10/2017

Ghibli & Wirbel S.p.A.

Via Circonvallazione, 5 - 27028 Dorno PV - Italia
P. +39 0382 848811 - F. +39 0382 84668 - M. info@ghibliwirbel.com

www.ghibliwirbel.com

100% MADE IN ITALY

MEMBER OF RIELLO INDUSTRIES

